



Fast Facts

RX8 Multi I/O Processor



This fast fact sheet provides basic reference information for the RX8 devices. The RX8 is available with two or five processors and the number of status lights depends on the model purchased. See the System 3 Manual for more detailed information.

Analog Input/Output. The analog I/O of each device is custom configured at the factory and can be accessed via a 25-pin connector on the front panel. Analog I/O is grouped in three blocks (A, B, and C) of eight channels for a total of 24.

Starting with block A and ending with block C, channels are numbered sequentially from 1 to 24. Three stickers on the face of the RX8 and located above the Analog I/O DB25 connector, are marked with the codes below to indicate whether each block is configured as Sigma-Delta or PCM and input or output.

sADC = Sigma-Delta Analog-Digital Convertors

sDAC = Sigma-Delta Digital-Analog Convertors

pADC = PCM Analog-Digital Convertors

pDAC = PCM Digital-Analog Convertors

Sigma-Delta converters provide superior conversion quality and extended useful bandwidths, at the cost of an inherent fixed group delay. When equipped with Sigma-Delta, the RX8 DAC Delay is 23 samples and the RX8 ADC Delay is 47 samples.

DB25 Connector Pinout

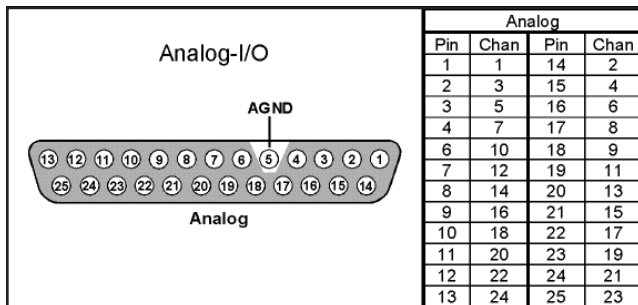

Status Lights

Pattern	DSP Status
Steady glow	Device on
Rapid flash	DSP cycle usage > 99%

Front Panel VFD Screen. The front panel VFD can display a variety of status indicators. Cycle through the options using the Mode button to the left of the display. Push and release the button to manually change the display options or push and hold the button for one second then release to automatically cycle through each of the following display options:

- Cyc: cycle usage
- Ovr: processor cycle overages
- Bus%: percentage of internal device's bus capacity used
- I/O%: percentage of data transfer capacity used

The VFD Screen may also report system status such as booting status [Booting DSP] or alert the user when the device's microcode needs to be reprogrammed [Firmware Blank].

Digital I/O. The TTL I/O circuits include 24 bits of programmable I/O [16-bits word addressable and 8-bits bit-addressable]. Digital I/O lines are accessed via the two 25-pin connectors on the front panel and can be configured as inputs or outputs. By default the Bits lights indicate the logic level (light when high) for the eight bit-addressable digital I/O lines. See the *System 3 Manual* for more information.

DB25 Connector Pinout

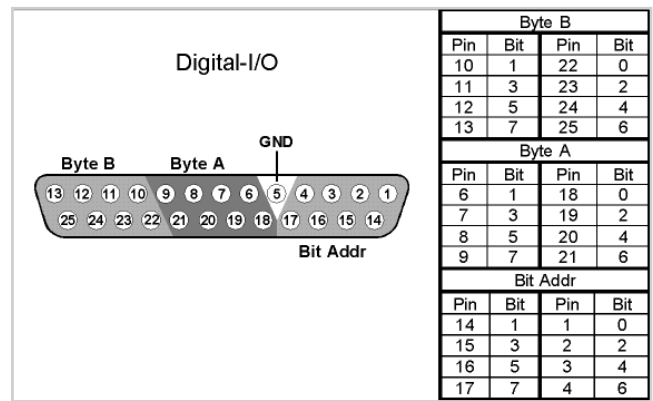

Using the PP24 for I/O

Digital I/O Connector

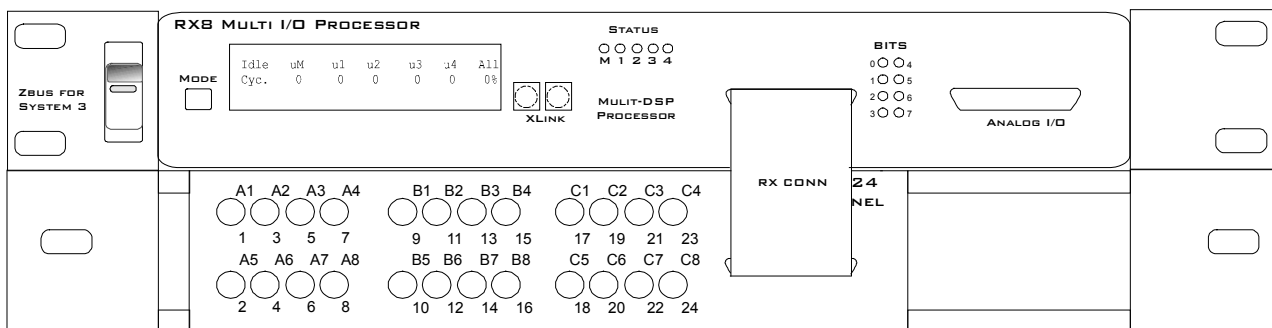

Device	A1-A8	B1-B8	C1-C8
RX8 Digital I/O Connector	Bit Addressable Digital I/O Channels 0-7	Digital I/O, Byte A Channels 0-7	Digital I/O, Byte B Channels 8-15

Analog I/O Connector

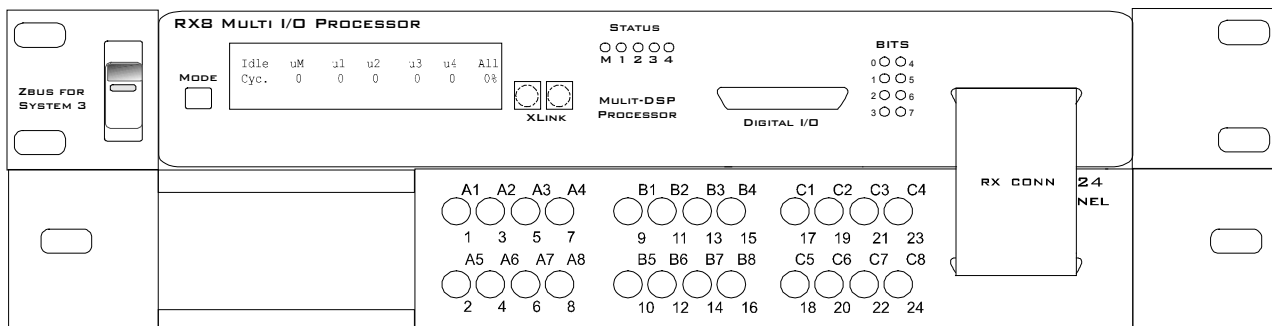

Device	A1-A8	B1-B8	C1-C8
RX8 Analog I/O Connector	Analog I/O Block A Channels 1-8	Analog I/O Block B Channels 9-16	Analog Output Block C Channels 17-24



support@tdt.com
www.tdt.com