

# ZIF-Clip® Headstage to DIP/MOLC Probes

ZIF-Clip® headstage adapters are available for use with a variety of electrodes. Standard operation for ZIF-Clip® headstages is shared differential [ground and reference are not tied together]. When using the ZIF-Clip® headstage with an adapter, it can be configured for single-ended operation by tying ground[G] and reference[R] connections together on the adapter. The reverse side of this fast facts provides pinouts for DIP AND MOLC BASED adapters.

**Adapter and Site Remapping.** ZIF-Clip® headstage adapters enable the use of third party electrodes; however, they do add another layer of complexity when determining which physical site corresponds to each channel number in the data. Remapping the channel numbers to a desired “map” can simplify the task of interpreting your data.

TDT provides an automated remapping function through Synapse’s Mapper gizmo. Mapper takes into account the pinouts of the electrode as well as those of any adapters to the TDT headstage.

When using the Mapper gizmo, the remap values are obtained by inputting the electrode pinouts in a “Custom” column in the Mapper interface and selecting the appropriate adapter in the second column. The Final Map is displayed at runtime.

For some setups you might also need to include a column in the table for the headstage [when using ZD64 or ZD96, or third party headstages]. The columns must be ordered left to right, beginning with the electrode. As a rule of thumb, you’ll need a column in the map table for each connection, up to the point when only TDT components [adapter, headstage] remain. Most TDT adapters and headstages have one-to-one connections, meaning that when connected, the pinouts represent the preamplifier channels.

Unfortunately, the electrode pinout does not necessarily match the adapter pinout. For example, the ZCA-DIP16 adapter [shown above-right] does not map directly to the NeuroNexus 16-channel electrode. Further, in the existing site map the channel numbers are not assigned in a logical order.

In the figure below, the mapper reorders the physical sites from 1 to 16 in terms of spatial depth. Site 1 in the desired site map, is physically connected to pin 9 on the electrode pinout. On the adapter pinout this channel corresponds to the amplifier channel number 15. Therefore, the Remap value for channel 1 should be the value 15.

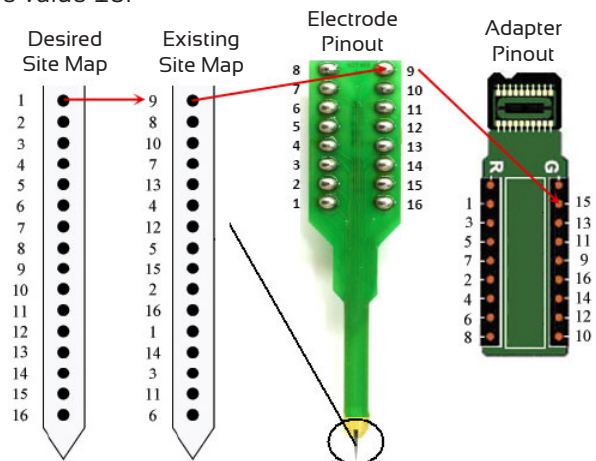

The table below represents the final site remapping for the mapper.

	<input checked="" type="checkbox"/> Mute All	<input checked="" type="checkbox"/> Active	<input checked="" type="checkbox"/> Active	Final Map
		Custom	TDT	
		Custom	ADAPTER	
		Custom	ZCA-DIP16	
1	<input type="checkbox"/>	9	8	15
2	<input type="checkbox"/>	8	6	1
3	<input type="checkbox"/>	10	4	13
4	<input type="checkbox"/>	7	2	3
5	<input type="checkbox"/>	13	7	16
6	<input type="checkbox"/>	4	5	2

In this case, it is easy to visually make this mapping connection, but in more complex adapter configurations, the Mapper can help to organize the information. See the Mapper in the Synapse Manual for more information.

**Important!** When using multiple headstages, ensure a single ground is used for all headstages. to avoid unnecessary noise contamination in recordings.

**Labs not using Synapse,** can use RVPdEx’s MCMAP and DataTable components or input from MATLAB with the use of parameter tags to remap instead.

## ZCA-DIP16

**Input connector:** 0.5 mm female 18-pin DIP socket  
**Connects to:** 16-channel male DIP connector  
**Use with:** ZC16, ZD32, ZCD16

Ground and reference pins are located on the DIP connector and may be tied together for single-ended operation.

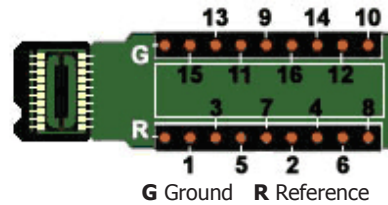

Pinouts are looking into the connector and reflect the preamplifier channels.

## ZCA-NN32

**Input connector:** 40-pin Samtec FOLC high density socket strip  
**Connects to:** 32-channel NeuroNexus A32-style probes  
**Use with:** ZC32, ZD32, ZCD32

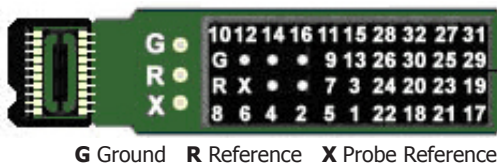

Pinouts are looking into the connector and reflect the preamplifier channels.

Ground and reference pins are located on the DIP connector and may be tied together for single-ended operation. X [Ref] is a reference pin that is connected from the adapter to the probe only. See the jumper configurations right for more information.

## ZCA-NN64

**Input connector:** 40-pin Samtec FOLC high density socket strip x 2  
**Mates with:** 64-channel NeuroNexus A64-style probes  
**Use with:** ZC64, ZD64, ZCD64

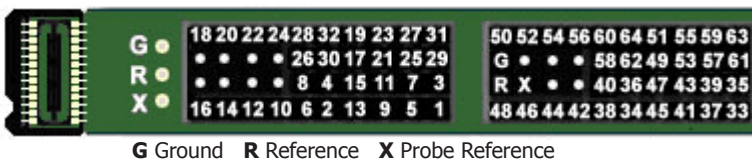

Pinouts are looking into the connector and reflect the preamplifier channels.

Ground and reference pins are located on the DIP connector and may be tied together for single-ended operation. X [Ref] is a reference pin that is connected from the adapter to the probe only. See the jumper configurations right for more information.

See the System 3 Manual for other available parts and information.

### 32 and 64 Channel Adapter Jumpers

#### Jumper Connection

#### Operation

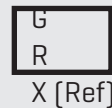

Shorts headstage ground and reference inputs together, yielding single-ended operation relative to ground.

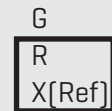

Shorts headstage reference input to the pin labeled X [a low impedance site on the probe] yielding differential operation relative to the voltage of the X [Ref] site.

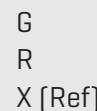

Headstage ground and reference separated and X [Ref] pin is not used, yielding differential operation relative to the voltage of the reference.



support@tdt.com  
www.tdt.com