

ZIF-Clip® Headstages to Omnetics Probes

ZIF-Clip® headstage adapters are available for use with a variety of electrodes. Standard operation for ZIF-Clip® headstages is shared differential [ground and reference are not tied together]. When using the ZIF-Clip® headstage with an adapter, it can be configured for single-ended operation by tying ground[G] and reference[R] connections together on the adapter. The reverse side of this fast facts provides pinouts for OMNETICS BASED adapters.

Adapter and Site Remapping. ZIF-Clip® headstage adapters enable the use of third party electrodes; however, they do add another layer of complexity when determining which physical site corresponds to each channel number in the data. Remapping the channel numbers to a desired “map” can simplify the task of interpreting your data.

TDT provides an automated remapping function through Synapse’s Mapper gizmo. Mapper takes into account the pinouts of the electrode as well as those of any adapters to the TDT headstage.

When using the Mapper gizmo, the remap values are obtained by inputting the electrode pinouts in a “Custom” column in the Mapper interface and selecting the appropriate adapter in the second column. The Final Map is displayed at runtime.

For some setups you might also need to include a column in the table for the headstage [when using ZD64 or ZD96, or third party headstages]. The columns must be ordered left to right, beginning with the electrode. As a rule of thumb, you’ll need a column in the map table for each connection, up to the point when only TDT components [adapter, headstage] remain. Most TDT adapters and headstages have one-to-one connections, meaning that when connected, the pinouts represent the preamplifier channels.

Unfortunately, the electrode pinout does not necessarily match the adapter pinout. For example, the ZCA-DIP16 adapter [shown above-right] does not map directly to the NeuroNexus 16-channel electrode. Further, in the existing site map the channel numbers are not assigned in a logical order.

In the figure below, the mapper reorders the physical sites from 1 to 16 in terms of spatial depth. Site 1 in the desired site map, is physically connected to pin 9 on the electrode pinout. On the adapter pinout this channel corresponds to the amplifier channel number 15. Therefore, the Remap value for channel 1 should be the value 15.

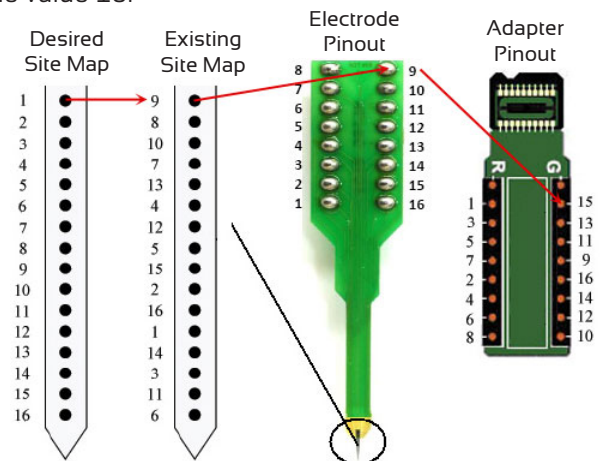

The table below represents the final site remapping for the mapper.

	<input checked="" type="checkbox"/> Active	<input checked="" type="checkbox"/> Active	Final Map	
<input type="checkbox"/> Mute All	Custom	TDT		
	Custom	ADAPTER		
	Custom	ZCA-DIP16		
1	<input type="checkbox"/>	9	8	15
2	<input type="checkbox"/>	8	6	1
3	<input type="checkbox"/>	10	4	13
4	<input type="checkbox"/>	7	2	3
5	<input type="checkbox"/>	13	7	16
6	<input type="checkbox"/>	4	5	2

In this case, it is easy to visually make this mapping connection, but in more complex adapter configurations, the Mapper can help to organize the information. See the Mapper in the Synapse Manual for more information.

Important! When using multiple headstages, ensure a single ground is used for all headstages. to avoid unnecessary noise contamination in recordings.

Labs not using Synapse, can use RpvdsEx’s MCMAP and DataTable components or input from MATLAB with the use of parameter tags to remap instead.

ZCA-OMN16

Input Connector: 18-pin female Omnetics nano dual row header
Connects to: 16-channel chronic Omnetics based probe
Use with: ZC16, ZD32, ZCD16

By default, the inputs are single ended, with reference and ground tied together. To make the inputs differential, cut the jumper between ground and reference (shown right).

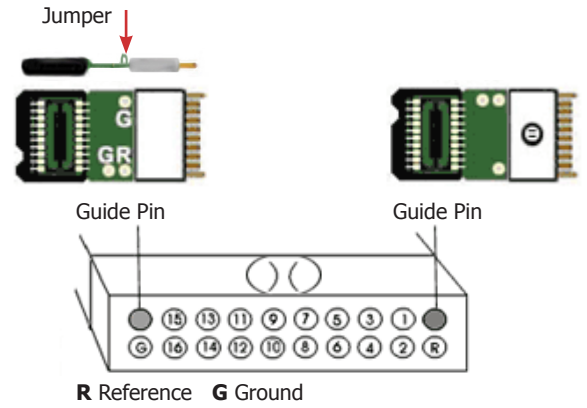

Pinouts are looking into the connector and reflect the preamplifier channels.

ZCA-OMN32

Input Connector: 36-pin female Omnetics nano dual row header
Connects to: 32-channel chronic Omnetics based probe
Use with: ZC32, ZD32, ZCD32

By default, the inputs are single ended, with reference and ground tied together. To make the inputs differential, cut the jumper between ground and reference (shown right).

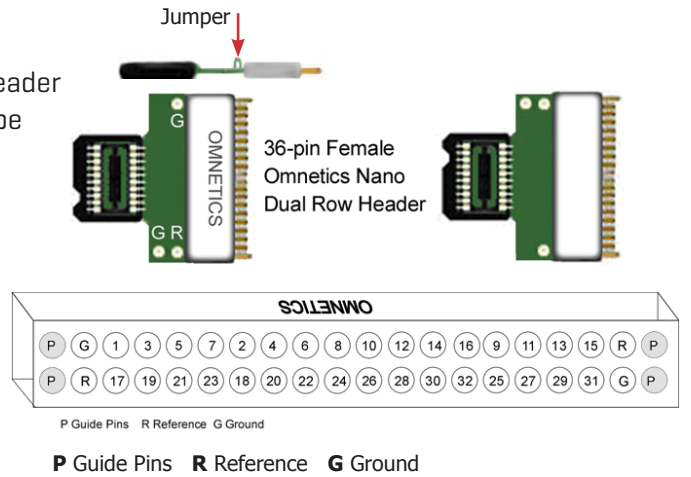

Pinouts are looking into the connector and reflect the preamplifier channels.

ZCA-OMN96

Input Connectors: 36-pin female Omnetics nano dual row header x 3
Connects to: 96-channel chronic Omnetics based probe
Use with: ZC96, ZD96, ZCD96

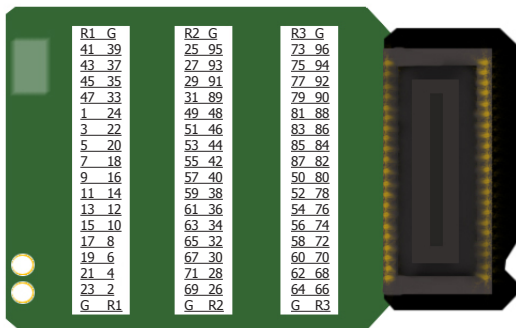

COMM Ground
IND Headstage Reference
R1 Probe Reference 1
R2 Probe Reference 2
R3 Probe Reference 3
G Ground
REF1 Probe Reference 1
REF2 Probe Reference 2
REF3 Probe reference 3

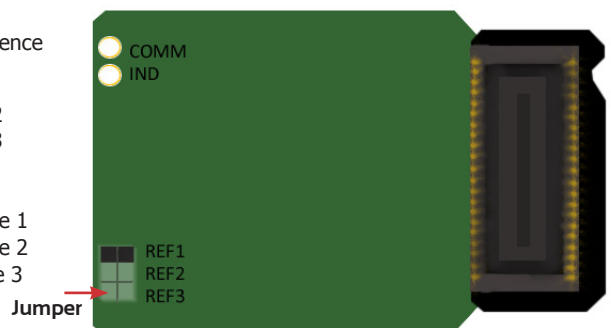

Pinouts are looking into the connector and reflect the preamplifier channels.

For single-ended operation, tie COMM [ground] and IND [headstage reference] together. For differential operation, use jumper to choose which probe reference [REF1, REF2, REF3] to use for all channels. Only one reference may be selected.

See the System 3 Manual for other available parts and information.